

# CR

Construction  
Resources



MULTI-FAMILY  
SURFACES COLLECTION

POMPEII QUARTZ

FORUM  
QUARTZ

## TABLE OF CONTENTS

3 COMPANY OVERVIEW

4 POMPEII QUARTZ

5 FORUM QUARTZ

6 GRANITE

7 SINK SPECS

8 PROJECTS

9 PARTNERSHIPS

10 LOCATIONS

### WHO IS CR?

Construction Resources' Multi-Family Division (formerly National Stoneworks) is the largest manufacturer and installer of countertops for the multi-family, hospitality and healthcare industries. For 45 years, we have been the preferred partner for prestigious developers and contractors in the Southeast. Our years of experience in the construction industry provides us with the proven ability to offer our customers expertise with engineering, drafting, fabrication and installation.

We provide excellent service and professionalism and are fully bondable and insured.

As a division of Construction Resources, we have a long-standing history for being first-in-class and are a part of a reputable network of 30 locations across five states, with more than 700 employees.

### CR MULTI-FAMILY INDUSTRY SECTORS

MULTI-FAMILY: Condominiums & Apartments

HOSPITALITY: Hotels & Resorts

HEALTHCARE: Independent Living & Assisted Living

### DOMESTIC FABRICATION FACILITIES

COUNTERTOP FABRICATION FACILITIES  
(GRANITE, QUARTZ, SOLID SURFACE & CULTURED MARBLE)

#### ATLANTA, GEORGIA

120,000 SF Automated Production Facility with 6,000 Slab Inventory

#### BIRMINGHAM, ALABAMA

20,000 SF Automated Production Facility with 500 Slab Inventory

#### SANTA ROSA BEACH, FLORIDA

50,000 SF Automated Production Facility with 2,000 Slab Inventory

### WHY ARE WE DIFFERENT?

- Resolved & determined to track client's construction schedule
- Financial strength - \$20mm bonding capacity at 1.5%
- World class countertop fabrication facilities
- Dedicated QC employees at all domestic & overseas facilities
- Deeply talented design department
- Highly experienced countertop installation teams
- Transparency with complete access to owners, management, & staff
- 45 years owned & operated
- Reputation built on trust





Featured Color: Valley White

Slab Size: 130" x 65" | 2CM or 3CM

Additional colors available upon request.

GROUP 1



GROUP 2



GROUP 3

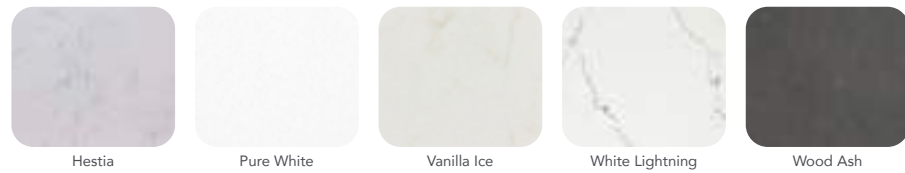

GROUP 4

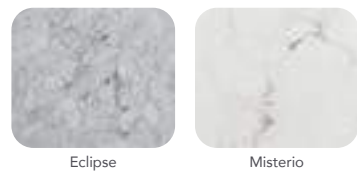

Featured Color: Calacatta Daydream

Slab Size: 130" x 65" | 3CM

GROUP 1

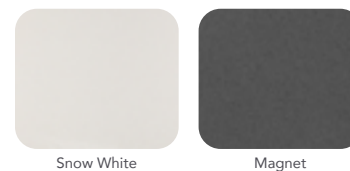

GROUP 2

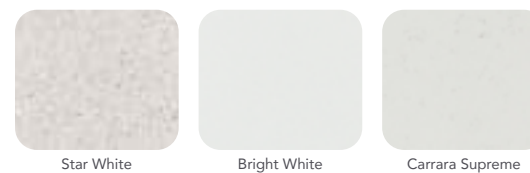

GROUP 3



GROUP 4

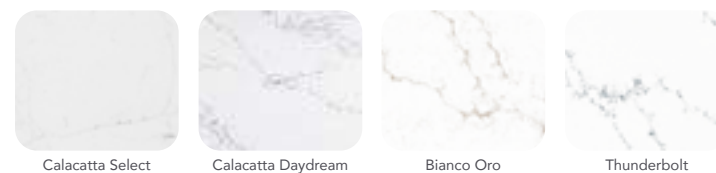



This material is a product of nature & subject to variation.

Additional colors available upon request.

**GROUP 1**



**GROUP 2**



**GROUP 3**



**GROUP 4**



**BATHROOM SINKS**



FRAME WHITE CH1910

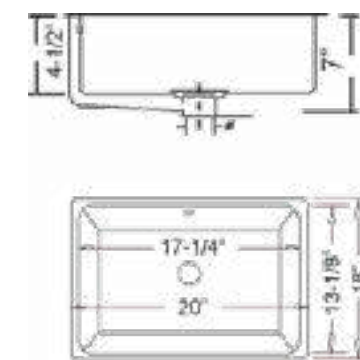

LOTUS WHITE YES933

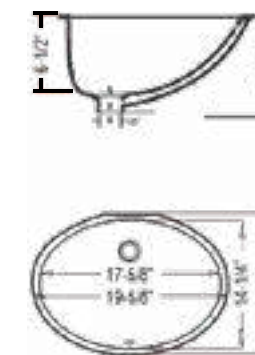

SCOOP WHITE RECTANGULAR UNDERMOUNT YES4410

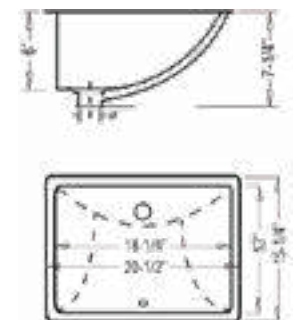

**KITCHEN SINKS**



50-50

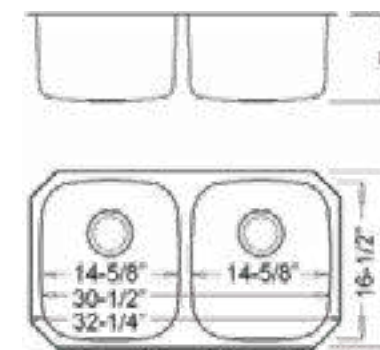

LARGE SINGLE BOWL

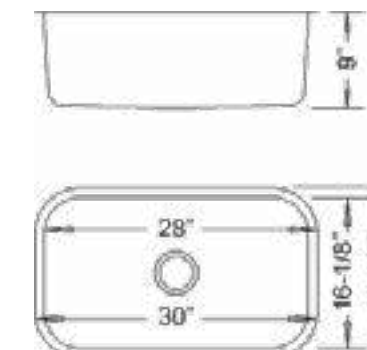

MEDIUM SINGLE BOWL

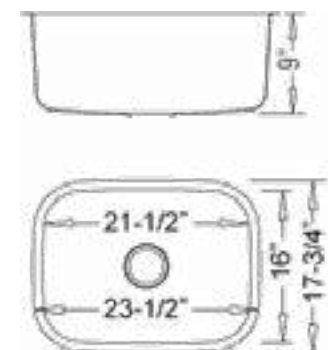

RZS600 - STAINLESS

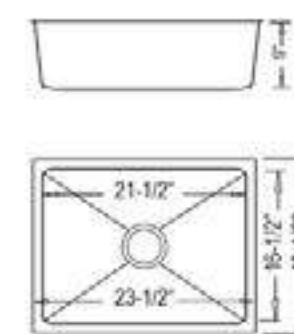

RZS300 - STAINLESS

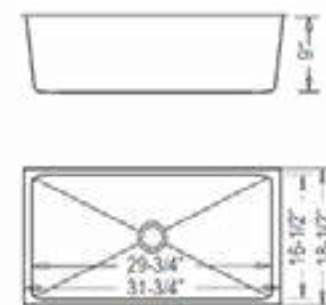

\*Additional sizes & styles available upon request.

NOTABLE PROJECTS

- ALLIANCE – Pullman Yards
- AMLI – Flatiron
- AVILA – 915 Glenwood
- BALFOUR BEATTY – Solitaire Brickell
- BRASFIELD AND GORRIE – Midtown Union Hotel
- BRASFIELD AND GORRIE – The Charles Condominiums
- CBG – Hazel Southpark
- CBG – Toll Decatur
- COASTAL CONSTRUCTION – Mimo Bay
- COASTAL CONSTRUCTION – FIU Sweetwater
- FAIRWAY CONSTRUCTION – Wisteria Hamilton
- FIRST FLORIDA – The Prime Orlando
- FORTUNE JOHNSON – Cama Street
- FORTUNE JOHNSON – Solis Gainesville
- FORTUNE JOHNSON – Solis Town Center Phase II
- FREESE JOHNSON – 630 Indian Street
- GABLES – Vinings
- GILBANE – The Sutton Condominiums
- GREYSTAR – 1382 Peachtree
- GREYSTAR – Elan Powers Ferry
- GREYSTAR – Everleigh Duluth
- GREYSTAR – Madison Yards
- GREYSTAR – Overture Powers Ferry
- HOAR CONSTRUCTION – The Gentry
- JE DUNN – 1812 Broadway
- JM WILKERSON – Avondale Hills
- JOHN MORIARTY & ASSOC. – 444 Brickell
- JUNEAU – Bryn House
- KAST CONSTRUCTION – Las Olas Walk
- LINCOLN PROPERTIES – Aspire Westside
- LINCOLN PROPERTIES – Pennington Bend
- McHUGH CONSTRUCTION – Kenect Nashville
- McHUGH CONSTRUCTION – West End
- McSHANE – Novel Harpeth Heights
- McSHANE – Stonepoint
- McSHANE – Woodward Crossing
- MOSS – Maizon Brickell
- NEW SOUTH CONSTRUCTION – Summerhill
- NEW SOUTH CONSTRUCTION – Suwanee Village
- NORTHWOOD RAVIN – 500 West Trade
- NORTHWOOD RAVIN – McEwen Blocks F&G
- NORTHWOOD RAVIN – Scott Crossing
- OXFORD – Oaks at Hidden River
- RENAISSANCE BUILDERS – Edgewood Phase II
- SKANSKA – 5th & Broadway
- STILES – 212 2nd Ave
- SUFFOLK – Park-Line Miami
- TURNER – 805 Lea
- VCC – Fordham Boulevard
- WORTHING SOUTHEAST – Heights at Northwinds
- YATES – 1111 Church St.

DEVELOPER PARTNERSHIPS

- ALLIANCE • AMLI RESIDENTIAL • CAMDEN PROPERTY TRUST • GABLES • GREYSTAR • JLB PARTNERS
- LINCOLN PROPERTIES • POST PROPERTIES • SWIRE PROPERTIES • THE MORGAN GROUP
- THE WORTHING COMPANIES TRAMMELL CROW RESIDENTIAL • WOOD PARTNERS • ZOM DEVELOPMENT

GENERAL CONTRACTOR PARTNERSHIPS

- BALFOUR BEATTY • BRASFIELD & GORRIE • CAMBRIDGE • CLARK BUILDERS GROUP • COASTAL CONSTRUCTION
- FIRST FLORIDA • FORTUNE JOHNSON • JE DUNN • JOHN MORIARTY & ASSOCIATES • JUNEAU • MCSHANE
- MOSS • NORTHWOOD RAVIN • SUFFOLK CONSTRUCTION • WORTHING SOUTHEAST BUILDERS



# VISIT ONE OF OUR SHOWROOMS FOR YOUR DESIGN NEEDS

## CR DESIGN CENTER

### DECATUR

224 Rio Circle  
Decatur, GA 30030  
404.378.3132

- COUNTERTOPS (Indoor Slab Gallery)
- SHOWER DOORS & MIRRORS
- SINKS & FAUCETS
- TILE & FLOORING

## CR LIGHTING

### DECATUR

252 Rio Circle  
Decatur, GA 30030  
770.932.3585

- LIGHTING
- FIREPLACES
- GARAGE DOORS

## CAMBRIA GALLERY

### BUCKHEAD

3096 Roswell Road  
Atlanta, GA 30305  
404.419.1250

- CAMBRIA QUARTZ COUNTERTOPS

## CR HOME ALABAMA

### BIRMINGHAM

223 W Oxmoor Road  
Birmingham, AL 35209  
205.943.0680

- COUNTERTOPS
- TILE

## FLORIDA BATH & SURFACES

### SANTA ROSA BEACH

5161 US Highway 98 West  
Santa Rosa Beach, FL 32459  
850.267.9424

- COUNTERTOPS
- FIREPLACES
- SHOWER DOORS & MIRRORS
- OUTDOOR LIVING
- SINKS & FAUCETS
- TILE & FLOORING

## CR FLOORING

### SANDY SPRINGS

4969 Roswell Road, Suite 130  
Sandy Springs, GA 30342  
770.945.4097

- TILE & FLOORING
- CARPET
- HARDWOOD

## CR OVERSTOCK GALLERY

### DECATUR

185 Laredo Drive  
Decatur, GA 30030  
404.378.3132

(Full Quartz Slab Overstock and Luxury Remnants)

- COUNTERTOP REMNANTS
- LIGHTING
- SCRATCH & DENT APPLIANCES
- RENEWED LUXURY SURFACES

## SEWELL APPLIANCE

### SANDY SPRINGS

7455 Trowbridge Road  
Sandy Springs, GA 30328  
404.255.0640

- APPLIANCES
- OUTDOOR LIVING

## ATLANTA GLASS & MIRROR

DECATUR | COLUMBUS  
GREENVILLE | COLUMBIA  
CHARLESTON

- MIRRORS
- LOCKS
- SHOWER DOORS
- CLOSET SYSTEMS

## CR DESIGN STUDIO

### BUCKHEAD

3098 Roswell Road  
Atlanta, GA 30305

- COMING SOON**
- ALL CR PRODUCTS

Under the Construction Resources brand, we also manage three other sister companies for multi-family, property management and slab distribution needs.

## CR MULTI-FAMILY

Decatur, GA  
954.349.1609

MULTI-FAMILY COUNTERTOPS

## ARD

Miami, FL | Tampa, FL | Jacksonville, FL  
Atlanta, GA | Charlotte, NC  
1.800.654.7721

APPLIANCES FOR APARTMENT COMMUNITIES

## UMI

Decatur, GA | Naples, FL | Tampa, FL  
Boynton Beach, FL | Jacksonville, FL  
Orlando, FL  
239.593.6995

COUNTERTOPS (Indoor Slab Gallery)

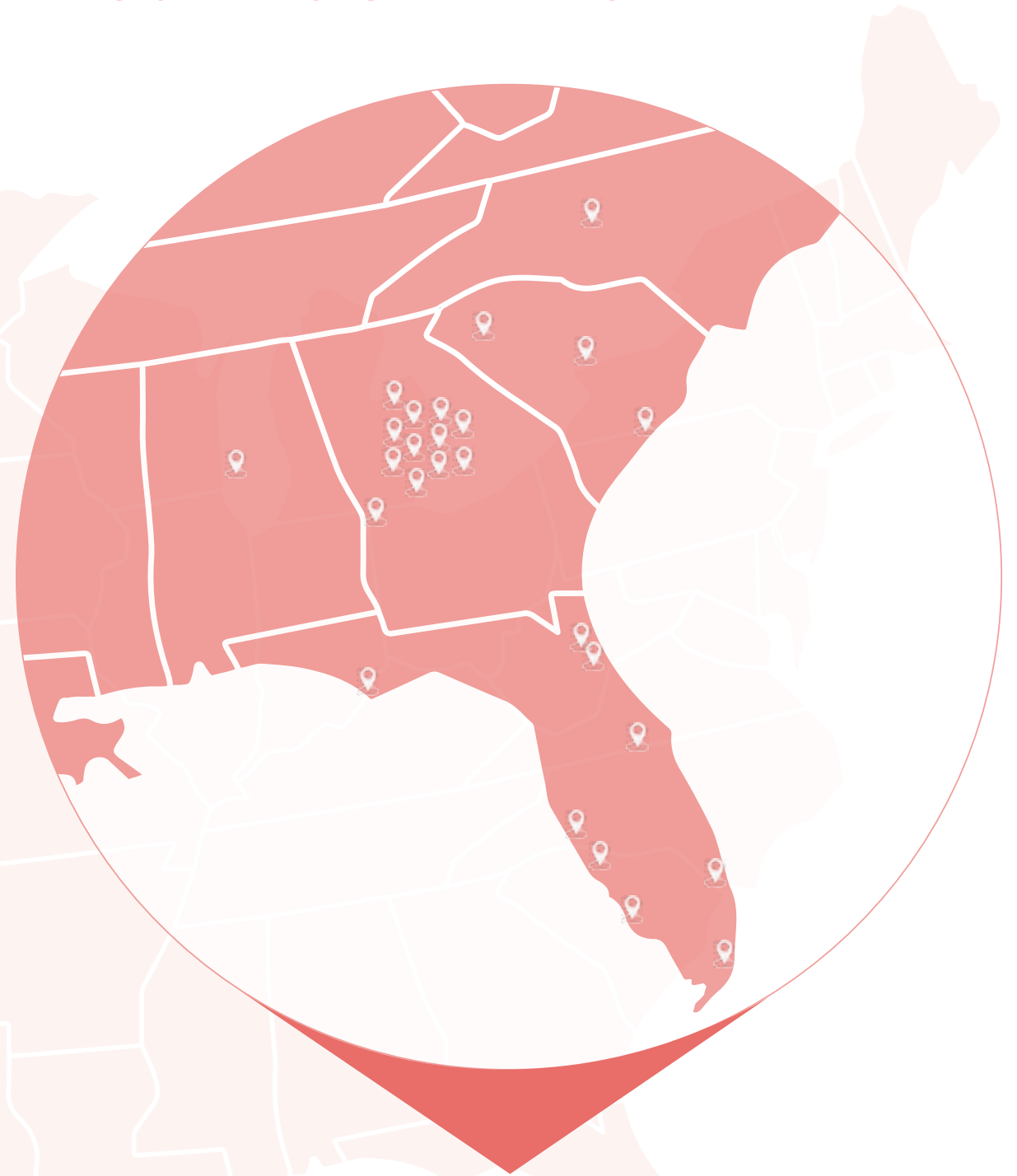

The products featured in the photos of this brochure, including flooring, appliances, and light and plumbing fixtures, are all available through our network of companies.

Visit any of our locations to see the spectrum of what we have available for your design needs.

# CR

---

## Multi-Family

APPLIANCES | COUNTERTOPS | FLOORING & TILE | FIREPLACES | GARAGE DOORS  
LIGHTING | OUTDOOR LIVING | SHOWER DOORS & MIRRORS | SINKS & FAUCETS

[www.ConstructionResourcesUSA.com](http://www.ConstructionResourcesUSA.com)

Revised: 05/2022